



CPKIDS MENU

Join CPKids Birthday Club at cpk.com

CPKids 10 and Under

Includes choice of a fountain beverage, lemonade, apple juice, milk or chocolate milk.
Complimentary drink refills.

PIZZAS

ORIGINAL BBQ CHICKEN 5.50
BBQ sauce, chicken and Mozzarella.

MUSHROOM PEPPERONI SAUSAGE 5.50
Mushrooms, pepperoni, Italian sausage, Mozzarella and tomato sauce.

HAWAIIAN 5.50
Pineapple, Canadian bacon, tomato sauce and Mozzarella.

TRADITIONAL CHEESE 5.00
with tomato sauce and Mozzarella.

PEPPERONI 5.50
Pepperoni, tomato sauce and Mozzarella.

PASTA or SALAD

Substitute multigrain penne for any pasta upon request.

CURLY MAC 'N' CHEESE 5.50
Add edamame .50

FUSILLI WITH MEAT SAUCE 5.50
with Parmesan.

BUTTERED FUSILLI 5.00
with butter or olive oil.

FUSILLI WITH TOMATO SAUCE 5.00

FUSILLI ALFREDO 5.50
with Parmesan cream sauce.

CPK SALAD 5.50
Crisp Romaine tossed with your choice of dressing, and topped with Cheddar Goldfish.[®]
[®] Without Cheddar Goldfish.

SWEETS

Available with the purchase of a CPKids Meal.

FRESH FRUIT 1.00
Fresh sliced pineapple and red seedless grapes. [®]

KIDS SUNDAE 1.00
Häagen-Dazs vanilla ice cream with triple-thick hot fudge, fresh whipped cream, rainbow chocolate chips and a cherry. [®]

BROWNIE 1.00
Topped with fresh whipped cream, Hershey's[®] chocolate syrup and a cherry.

CHICKEN

GRILLED CHICKEN BREAST 6.00
Served with baby broccoli.

CRISPY CHICKEN 6.00
Served with baby broccoli, herb ranch and ketchup.

FIND THE FUN INSIDE

[®] Gluten-Free

HAVE SOME SUMMERTIME FUN!

There's a lot going on at this playground ... jump in and join the fun!
When you're done playing, color in the fun!



CONNECT THE DOTS

See what this cool kid is riding.

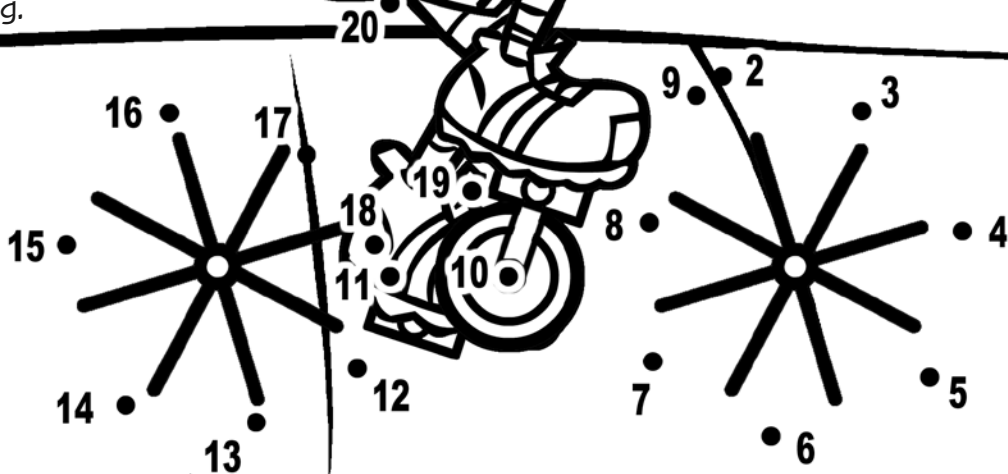



HERE BIRDIE, BIRDIE!

Find, count and circle all the birds hidden in this picture.

DRAW WHAT YOU LIKE TO DO IN THE SUMMER



ANSWER!

HERE BIRDIE, BIRDIE!

There are 22 hidden birds

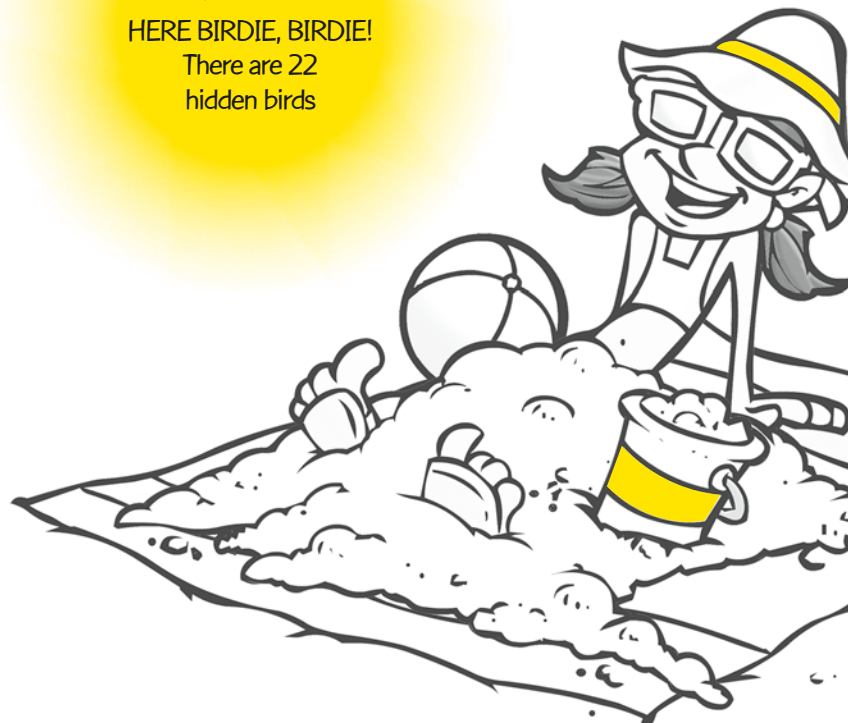

"Gluten-Free" designations are based on information provided by our ingredient suppliers. **Warning:** normal kitchen operations involve shared cooking and preparation areas. **We are therefore unable to guarantee that any menu item is free from gluten or any other allergen, and we assume no responsibility for guests with food allergies or sensitivities.** Please inform a manager of any allergies when ordering.

Please see our nutritional guide. Additional nutritional information is available upon request.

Before placing your order, please inform your server if anyone in your party has a food allergy. Consuming raw or undercooked meats, poultry, seafood, shellfish, or eggs may increase your risk of foodborne illness, especially if you have certain medical conditions.

A 2,000 calorie daily diet is used as the basis for general nutrition advice. However, individual caloric needs may vary. Visit mypyramid.gov for more information. The Dietary Guidelines for Americans recommend limiting saturated fat to 20 grams and sodium to 2,300 milligrams for a typical adult eating 2,000 calories daily. Recommended limits may be higher or lower depending upon daily calorie consumption. The nutritional information in this menu is derived from information provided by our suppliers, analyses using industry standard software, and published resources, including those from the U.S.D.A. All nutritional information given is based on standard recipes and serving sizes and California Pizza Kitchen cannot guarantee that the information provided is completely accurate as it relates to the prepared menu items at each restaurant. Variations in serving sizes, preparation techniques, product assembly supply sources and regional and seasonal differences in ingredients, may affect the nutritional values for each menu item. You should expect some variations in the nutrient content of the products purchased in our restaurants, and greater variation if an order is customized or topping combinations are altered. All nutrition information for branded beverages was provided by the manufacturers.

©2012 CPK. CALIFORNIA PIZZA KITCHEN and CPK are registered marks of CPK Management Company.

♻️ Printed on 100% recycled paper.